

This paper not to be cited without prior reference to the author

International Council for  
the Exploration of the Sea.

C.M. 1974/C: 29  
Hydrographic Committee.



Operating Experiences with an ultrasonic current meter.

By

Trygve Gytre

Institute of Marine Research  
Directorate of Fisheries  
Bergen Norway.

## Introduction

The need for accurate determination of current velocity in the sea, estuaries and rivers is increasing. In particular there is a need for an instrument that combines high sensitivity with fast response. In cooperation with the Christian Michelsens Institute a two axis ultrasonic current meter has been developed that shows great promise for improved current measurements in the future.

## Theory

The instrument works on the travel time difference principle which means that it measures the fluid flow past the meter by sending sound in opposite directions along the same acoustic path. The time difference required for the sound to travel with and against the current is a linear measure of the component of water velocity in the sonic path.

## Sensors

The sensors required for one-component measurements are two identical acoustic transducers A and B (Fig. 1). Each transducer contain a piezoelectric crystal that is thickness resonant in the ultrasonic range from 1 - 10 MHz. The transducers are lined up at an internal distance  $l$  and simultaneously excited with electric pulses at a fixed repetition rate of say 30 Hz or more depending on the bandwidth required. At each impulsation a short burst of acoustic oscillations are started at the two opposite transducers. The acoustic signals are received by the transmitters now acting as receivers after a time delay  $t_1$  and  $t_2$  respectively depending on the speed of propagation  $C$  and the fluid velocity component in the sonic path  $v_p$ . It can be shown that the up and downstream travel time difference  $t = t_2 - t_1 = \frac{2 \cdot l \cdot v_p}{C^2}$  (ref. 1)

This equation is valid even if the sound path deviates from the straight line between A and B f. exc. via a reflector C as indicated on fig. 1. Thus  $l$  in fact represents the actual sound path projection on the axis A-B.

### Necessary time resolution

For oceanographic studies a path length of appr. 15 cm is practical. If one wants to measure a current velocity of 1 cm/sec the insertion into eq. 1 gives:

$$t = \frac{2 \cdot 1.5 \cdot 10^{\div 1} \cdot 10^{-2}}{1.5^2 \cdot 10^6} \cdot 1.35 \cdot 10^{-9} \text{ sec}$$

Time detection in the order of one nanosecond or less is thus necessary to obtain sensitivities of one cm/sec or better.

### Design goals of an acoustic current meter.

When designing a current meter the sensor part should be constructed to match the requirements for an ideal current meter as close as possible. The most basic requirements for the ideal current meter is:

1. It will respond to the component of current along one axis.
2. Its response will be maximum when aligned with the current and fall off as the cosine of the angle between the meter axis and the flow axis.
3. It will have an instantaneous, linear response with zero bias from appr. one mm/sek to several meter/sec.
4. It will be insensitive to variations in the physical properties of the water - ie. changes in temperature, density, turbidity.
5. For a moored current meter, measuring horizontal mean currents - calling the sensitivity in the horizontal plane the horizontal cosine response and sensitivity to vertical current components the vertical cosine response, then accurate horizontal and vertical cosine responses are required if the sensor is to correctly measure mean horizontal currents in the presence of orbital wave motions, mooring induced vertical instrument motions or in any current region with a significant component of vertical flow.

### Mechanical design

the purpose of the current sensor mechanics is:

1. To protect the piezoelectric sensors from moisture and water pressure and at the same time provide an acoustic path for the ultrasonic signals.
2. Avoid obstructing the fluid flow along the acoustic path during measurement to ensure a true cosine response.

### Design problems

A problem with the sensor design is that when the flow is along the transducer axis the wake behind the leading probe and ahead of the trailing probe slows the water and thus reduce the average speed along the path. If the angle between the flow and the transducer axis is more than appr.  $30^{\circ}$  the effect is no longer observable.

To overcome this problem a mirror reflecting system has been constructed Fig. 2 shows the sensor construction in detail.

The piezoelectric crystals are cemented to the inside of brass discs which are glued to the probe. Two pairs of transducers - mounted  $180^{\circ}$  apart protrude from the vertical axis by  $45^{\circ}$ . The ultrasonic signals are transmitted between the probes via a mirror positioned  $45^{\circ}$  away from the current axis in the horizontal projection. The transducer tips have been machined to give the smallest possible disturbance of the water underneath the probes.

### Electronic design

The purpose of the electronic circuits is:

1. To detect the minute differences in the travel time and convert it to an analog signal that is proportional to the current component in the x and y - direction.
2. Compensate for the variations in sensitivity and zero baseline that may be caused by variations in the sound velocity of the water and parameter variations in the electronic components.

Fig. 3 shows a block diagram of the electronic circuits.

A master oscillator tuned to a fixed frequency of appr. 1 MHz drives a divide by 14 counter. Each time the most significant bit goes high, - appr. 60 times pr. second - the transducers are pulsed. The detecting circuits for the two transducer pairs are activated one at the time - ie. 30 times pr. second.

Conversion from time delay to analog electric signal is obtained by letting the received signals from transducer A start a high speed ramp generator and those from transducer A stop it.

The ramp amplitude is sampled and multiplexed to terminal 1 and 2 in sequence via an amplifier which gain is digitally controlled by the acoustic travel time between the probes. The gain setting is made to counteract the variations in sensitivity caused by the variations in C according to eq. 1. Before the ramp amplitude is multiplexed to the output sample and hold circuit, the baseline is controlled by a feedback servo that simulate zero current at the transducers and checks if the ramp amplitude corresponds to zero. If not a compensating DC voltage is added or subtracted.

The output signal from the current meter as presented on the output terminals are two DC -voltages in the range  $\pm 10V$  corresponding to positive and negative currents in all four quadrants. The DC-signals are updated appr. 30 times pr. second each offering a theoretical bandwidth of 15 Hz. By sampling at a faster rate any practical bandwidth may be obtained if required.

#### Results obtained with the current meter

Fig. 4 shows a photo of a profiling type two axis current meter. In addition to the current sensor this instrument contains a pressure sensor and a compass. The instrument is powered from above via a cable which also returns the measuring signals from the instrument. This instrument requires appr. 1 W of from the batteries.

## Results

### Calibration

Fig. 5 shows a plot of the lower part of the calibration curve. Within the precision of the towing tank the response is completely linear. The sensitivity is 37,5 mV/cm/sec which with a total output span of 0 - + 10V gives a dynamic range of 0 - + 2,65 m/sec. The meter noise level is appr. 1-2 mV which makes the detection of water velocities of 1 mm/sec possible. The zero baseline when the instrument is inserted in calm water for long periods (several weeks) is stable within a few mV.

### Operating experience

A profiling instrument of a similar type as shown on fig. 4 has been tested in several field experiments by the Harbour and River laboratory at Trondheim covering lakes, rivers and fiords.

Fig. 6 and 8 show some representative results. The River and Harbour laboratory is in particular satisfied with the combination high sensitivity and fast response which f. exc. has made it possible to study turbulence in rivers and estimate net flow in a lake.

A special version developed for a free falling instrument in a joint project between Geophysical Institute - Bergen and Yale University - New Haven has satisfactorily measured shear currents down to several hundred meters. This particular instrument also simultaneously measured conductivity, temperature and pressure. The data were recorded on a digital tape recorder at a rate of 400 bits per second.

### Examples on operating experience

#### Profiling of a lake

A 27 foot boat was three point moored at five points along a straight line across the lake Mjøsa at Vingerum. Fig. 6 shows the resulting current picture. The current towards south which is induced by the

outstreaming river. Lågen is concentrated on the west end beach due to friction and earth rotation. A compensating current towards north flows at the east end beach. The south-bound current is slowed at the surface due to wind from south. The actual flow in the river Lågen according to the river authorities was given as  $450 \text{ m}^3/\text{sec}$  which is in remarkably good correspondence.,

#### Observations of velocity fluctuations in a strongly stratified estuary.

In order to evaluate the energy transfer across strong pycnolines, the flow at the outlet of Nidelven river was measured using the railroad over the river as a stable platform for the current measurement. The depth of the river at this place is appr. 7 meter. Observations of the vertical current velocity profile were made at 6 tidal phases.

Fig. 7 shows the calculated kinetic energy density spectra for three tidal phases.

The spectral characteristics which were found to be a common feature at the three tidal phases were:

1. Large energy densities at wave lengths of the order of magnitude of the thickness of the upper layer ( $D$ )
2. A reduction of energy density in the upper layer proportional to  $K^{-3}$  at smaller wavelengths.
3. Larger energy densities in the lower layer at wave lengths approaching the size of the current meter.

#### Fiord observation

A profiling of the current in the Jøsenfjorden south of Bergen was carried out from an anchored fishing vessel. The instrument was lowered into the fiord at variable depths from 25 - 2.5 meters, and the current fluctuations during appr. 30 minutes were recorded.

Fig. 8 shows an example of the observed current. As shown the current showed great fluctuations. The reasons for the fluctuations is supposed to consist of contributions from:

1. Vessel movements caused by wind and waves
2. Internal waves
3. Transient currents caused by f. exc. tides, meteorological conditions etc.
4. Shortperiodic waves caused by surface waves, internal waves, turbulence etc.

#### Comments to fig. 8.

The recording shows remarkably intense short term fluctuations. To study the true long term currents, the short term variations in the currents must be removed. This can only be done with vectorial integrating current meter with fast response like the ultrasonic current meter. Alternative current meters like Aanderaa and Echman will inevitably transfer energy from the shortperiodic to the longperiodic part of the energy spectrum when measuring in a water with such fast fluctuations as observed in the Jøsenfjorden.

To avoid errors in estimating the current, field measurements should start with a short pilot measurement of the current with a fast and continuously indicating current meter to see which frequencies that carry noteworthy amplitude. When this has been done the optimum integration period can be set.

#### Recording

Work is now being done to incorporate a magnetic flux gate compass into the current meter and to supply it with a magnetic recorder. The recorder chosen is manufactured by Sea Data Inc. (Newton, USA) and can record appr. 10 million bits of data at a rate of four hundred bits per second.

#### Mooring

By measuring the two current components and the compass, the true current vector can be calculated independent of the instrument orientation. This allows simplifications in the mooring system. Fig. 9 shows the planned mooring system for a self contained recording instrument. It is



believed that the proposed system will simplify the procedures for setting out and taking in the instruments at sea.

Further plans.

Further testing with several recording prototypes of the ultrasonic current meter will take place in the North Sea from October 1974.

Experiments with the profiling current meter will also be carried out during the rest of 1974.

Ref. 1: Audunson, Gytre and Laukholm:

"Measuring current with an ultrasonic transit time difference current meter"

American Soc. of Civil Engineers, Hydraulicdivision 1974. (To be published).

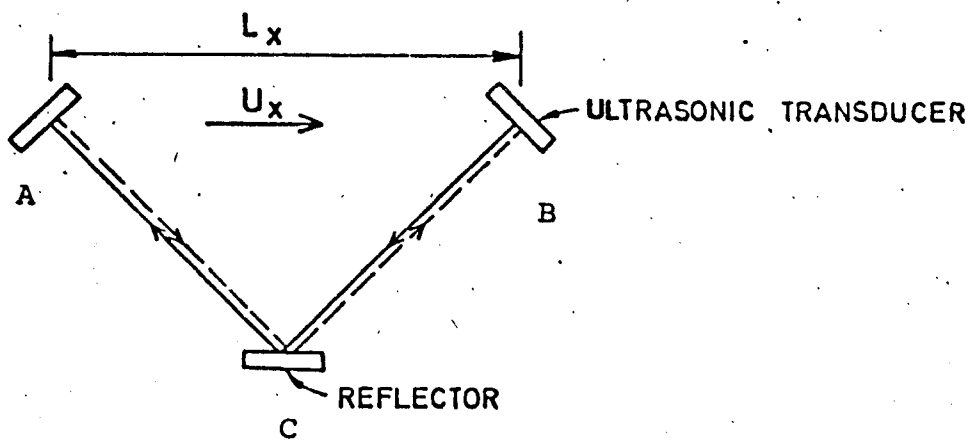

Fig. 1. Acoustic signal path.

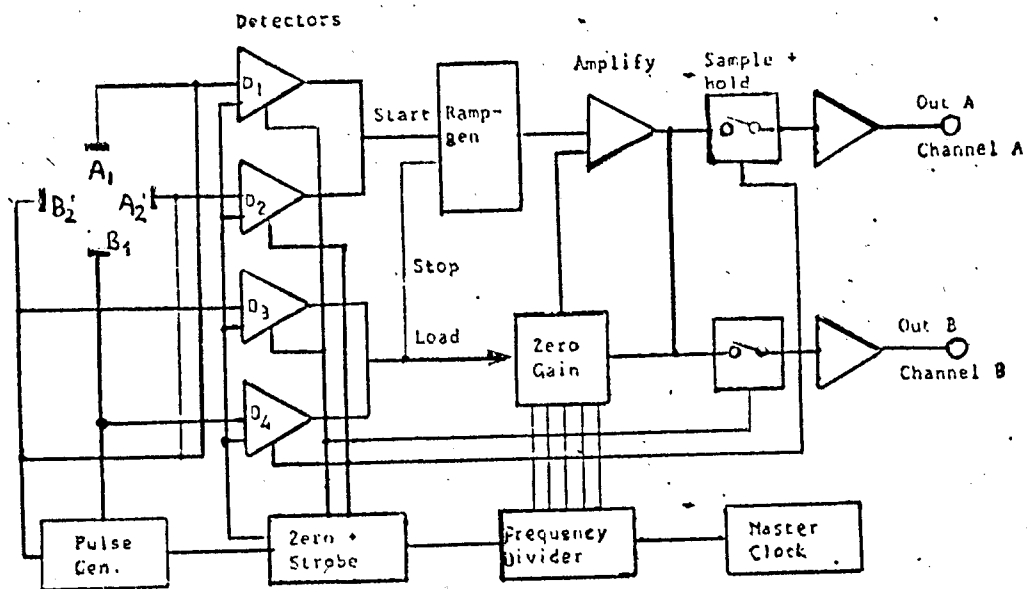

Fig. 3 Current meter block diagram.

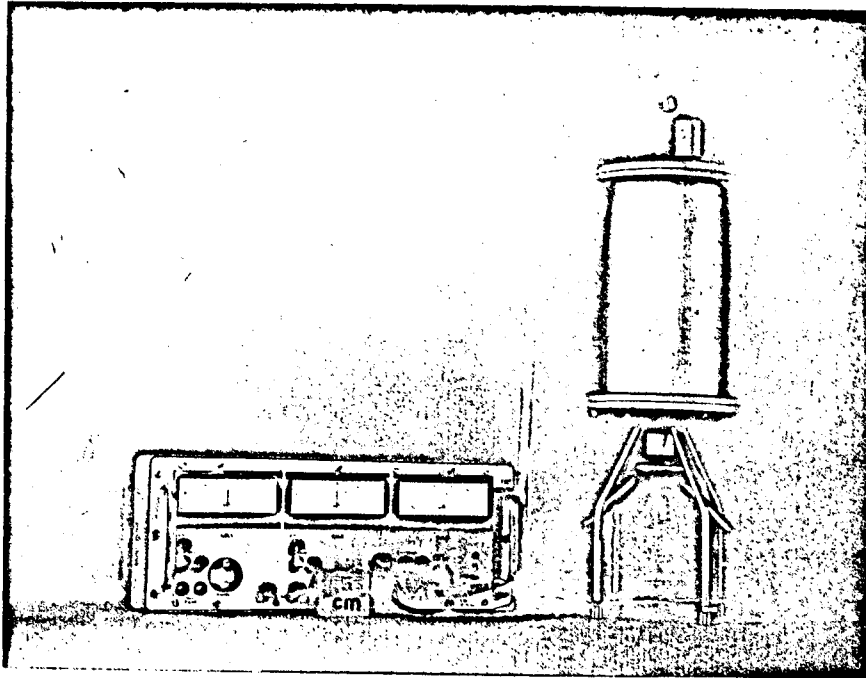

Fig. 4. Prototype profiling current meter with cable and deck unit containing batteries and read out facilities.

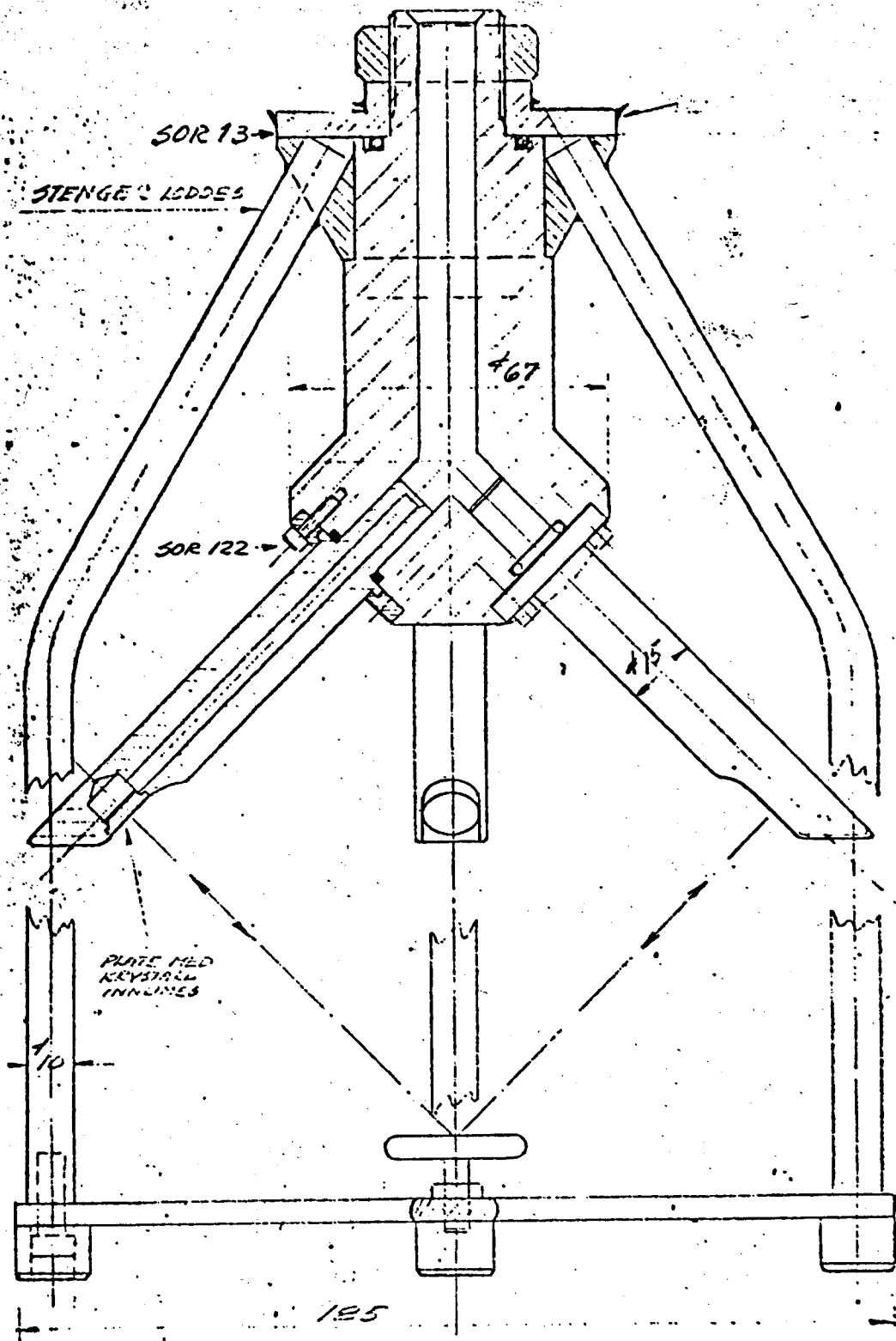

Fig. 2. Sensor unit design.

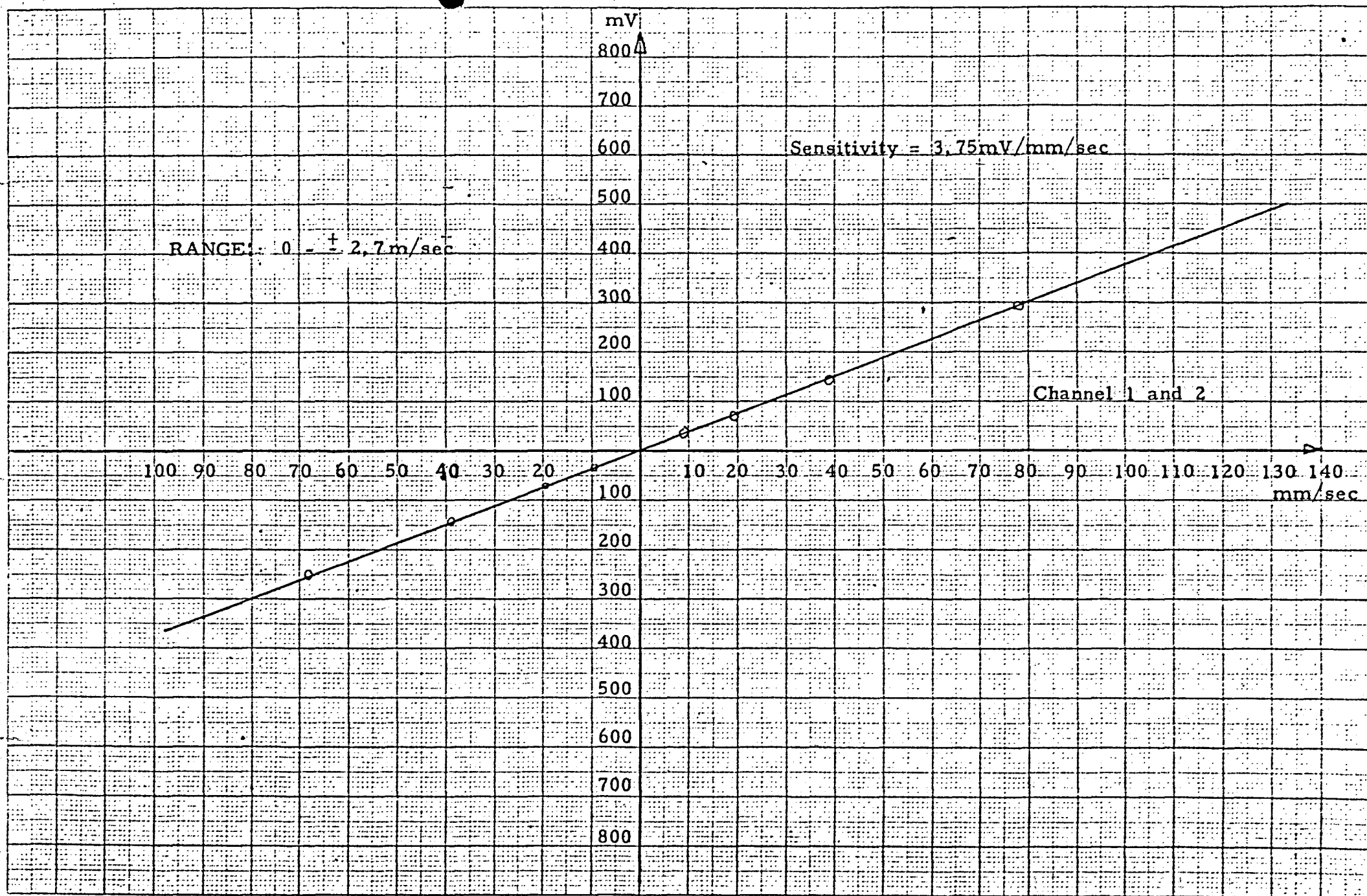

Fig. 5: Calibration curve

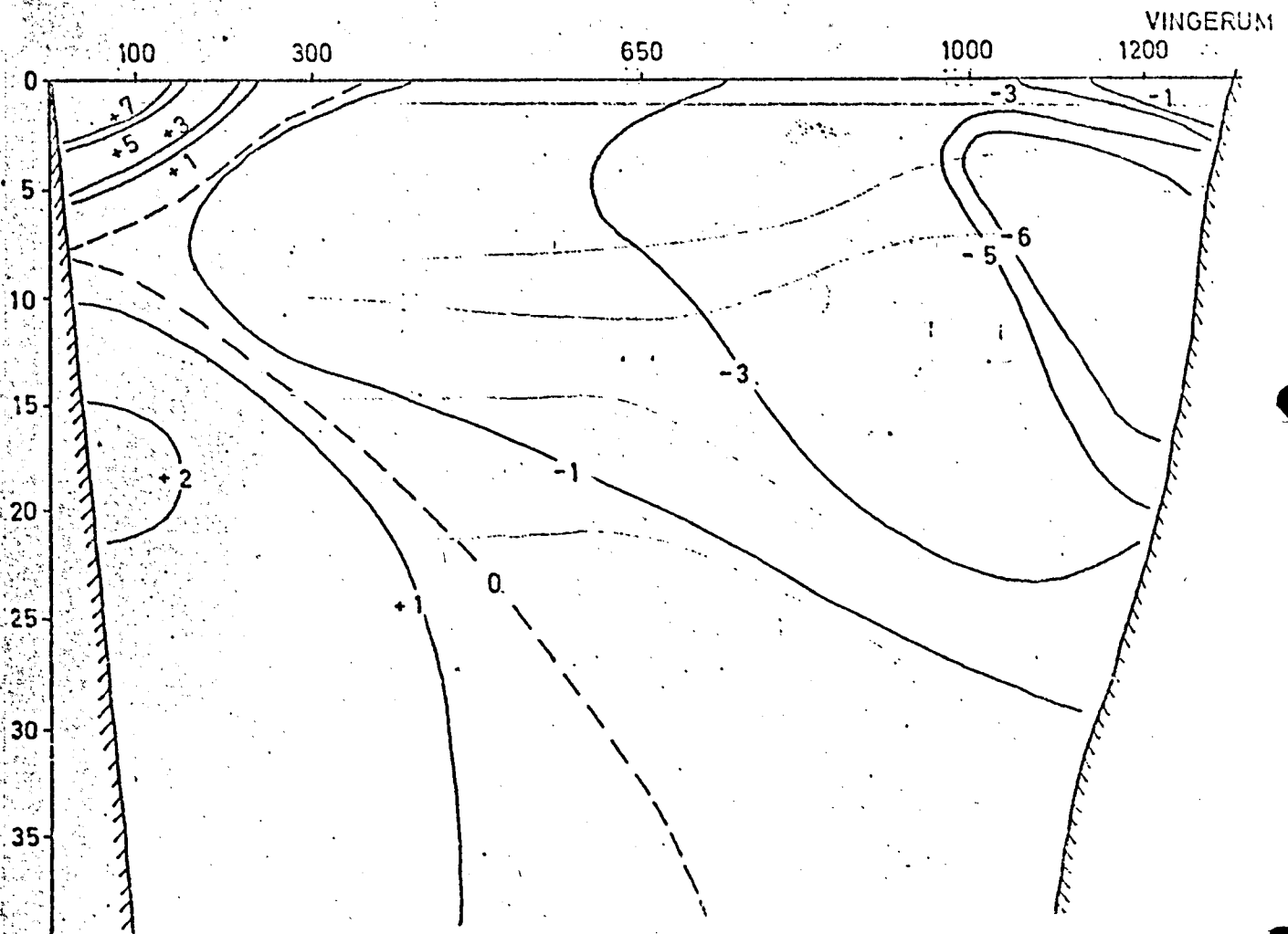

Fig. 6. Current in the lake MJØSA at VINGERUM MAY 14 1974  
 + denotes current towards NORTH (cm/sec)  
 - denotes current towards SOUTH - " -  
 (Measured by the River and Harbour Laboratory).

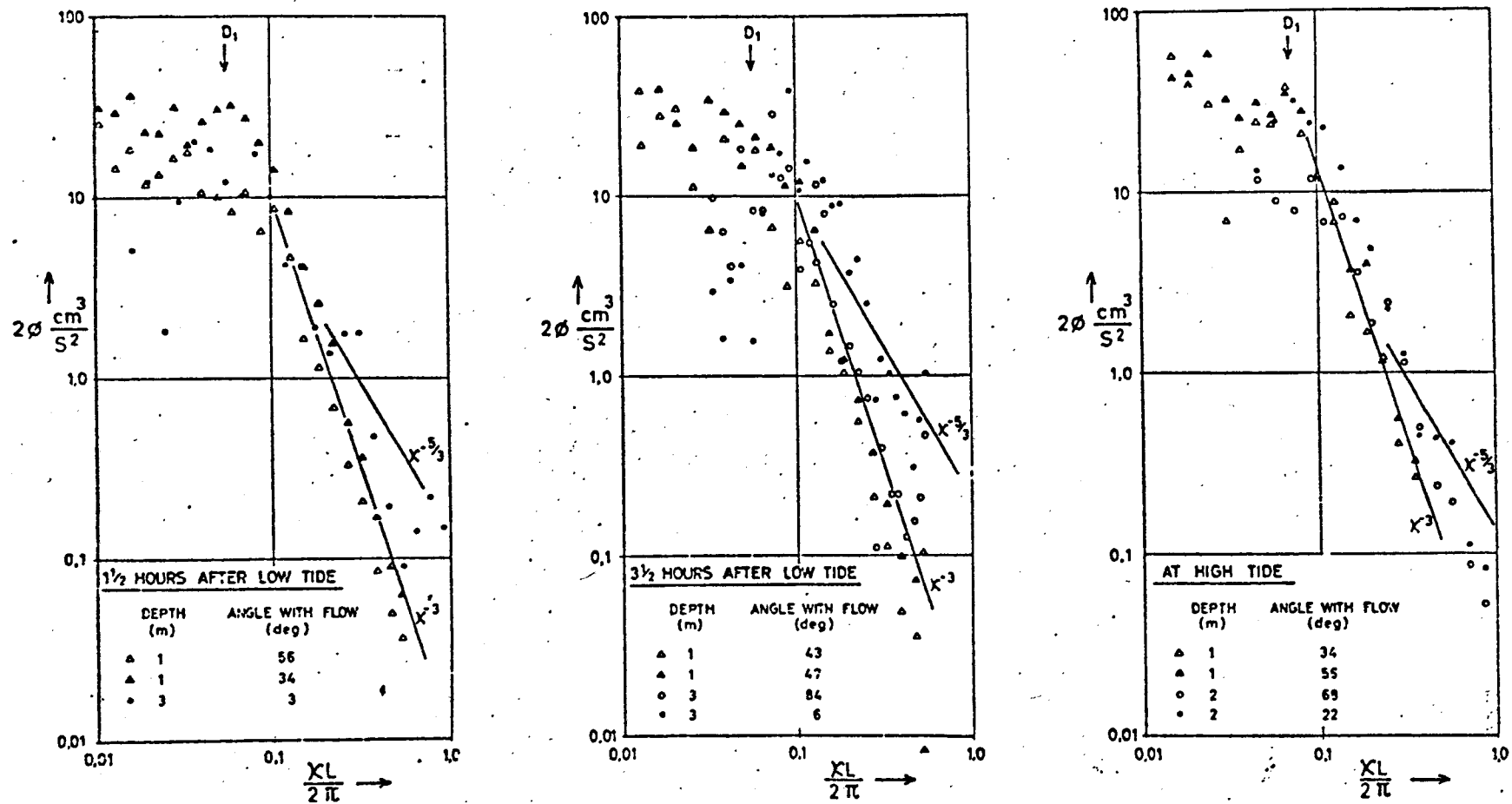

Fig. 7.

One dimensional kinetic energy density spectra at three tidal phases.  
(Measured by the River and Harbour Laboratory).

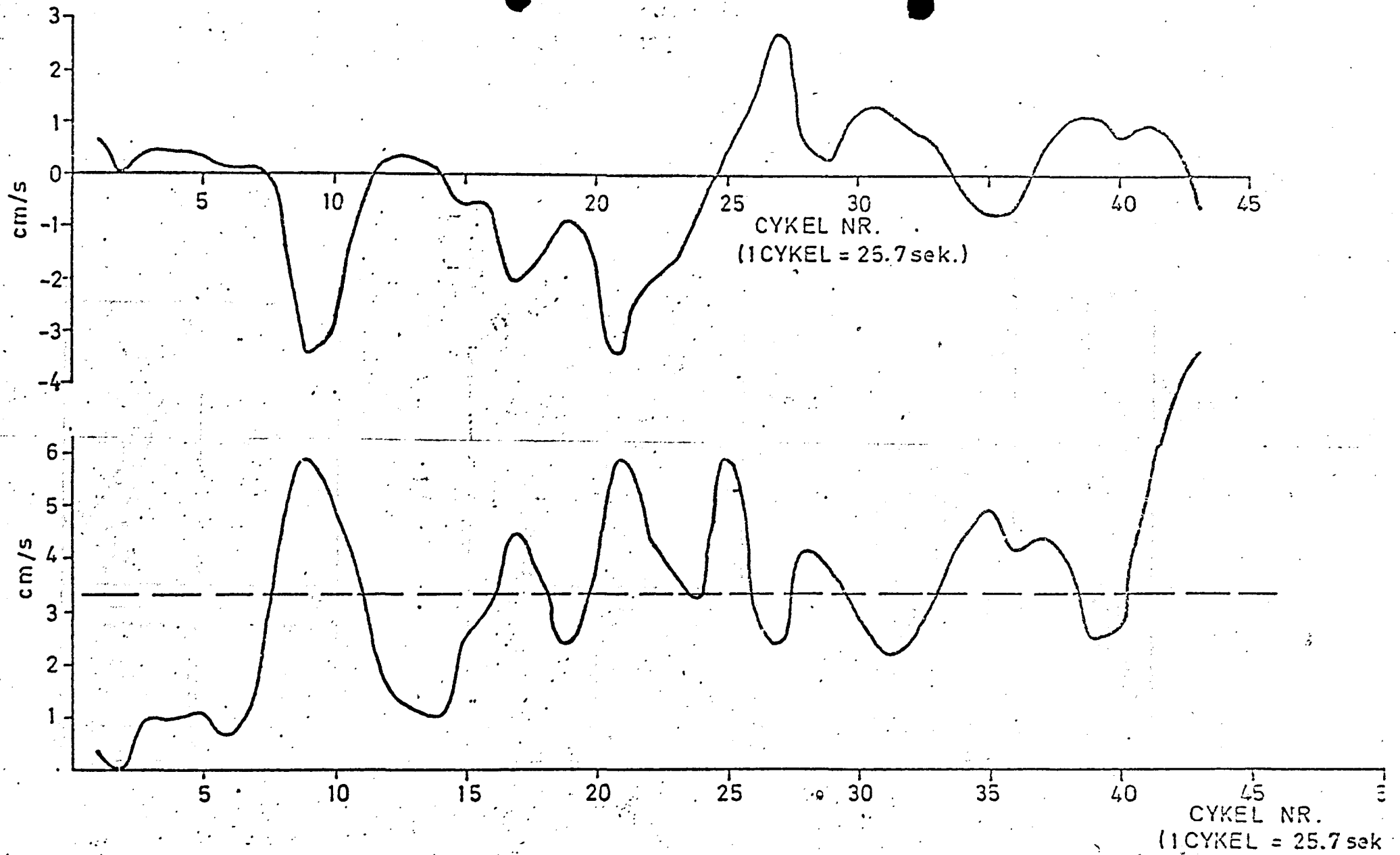
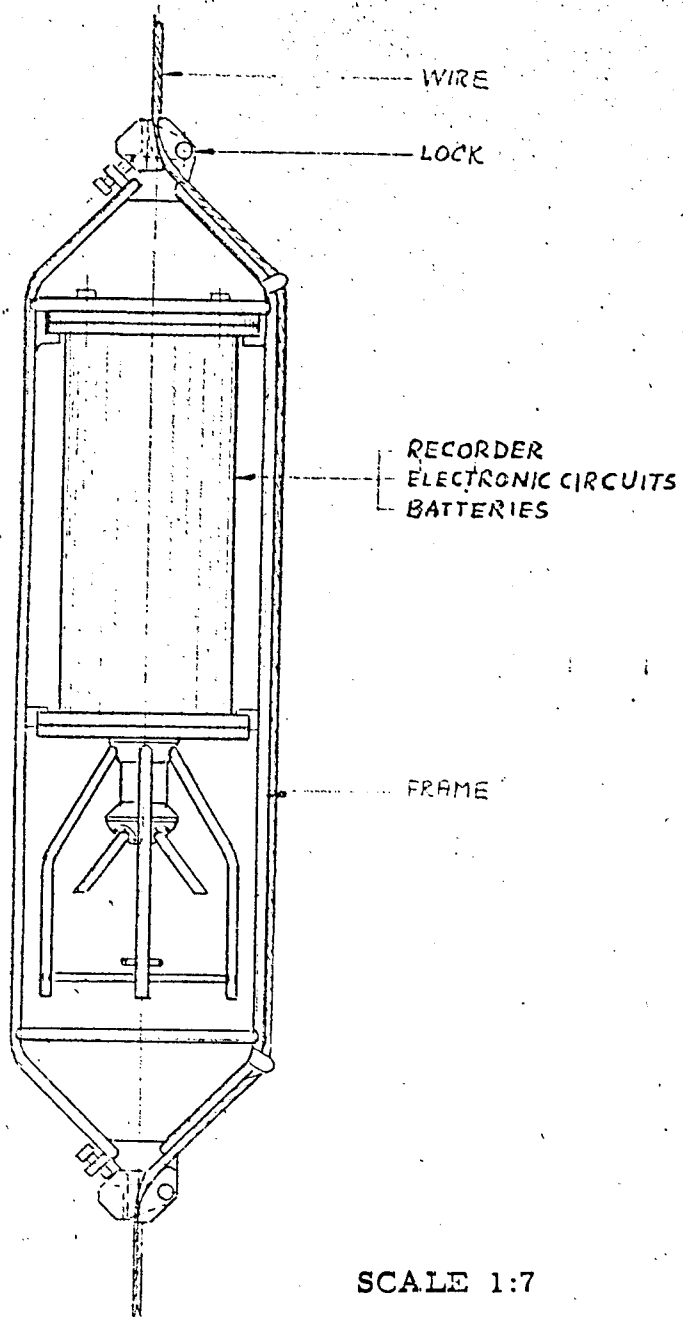

Fig. 8. Current fluctuations observed in the JØSENFJORDEN at 25 meter.

Upper trace: Current component towards  $135^\circ$ , Lower trace: Current component towards  $225^\circ$   
 (Measured by the River and Harbour Laboratory).





SCALE 1:7

Fig. 9. Moored current meter.